

CAVIUS

PRODUCT NAME: CAVIUS CO ALARM, 10 YEAR 40MM

PRODUCT NUMBER: 4002

CO
ALARM



DANISH
DESIGN



10 YEAR
BATTERY

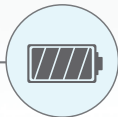

100%
TESTED

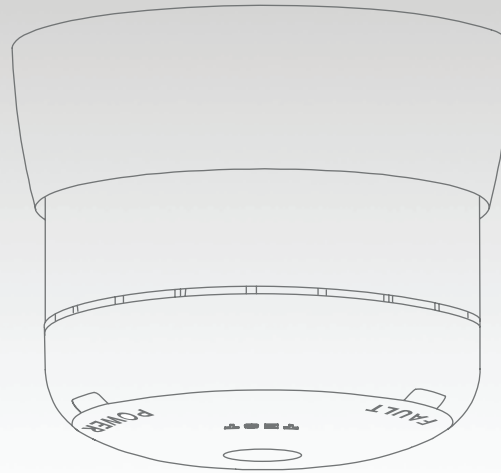

10 YEAR
CO
ALARM





CAVIUS

PRODUCT NAME: CAVIUS CO ALARM, 10 YEAR 40MM

PRODUCT NUMBER: 4002

PRODUCT DATA:

DEVICE TYPE:

Carbon monoxide alarm device.

USAGE:

Designed for installation in private homes, camping trailers, mobile homes and caravans.

FUNCTION:

The alarm will make a CO sensor reading every 30 seconds if the concentration is less than 200ppm. At 200ppm or higher the readings will be made every 10 seconds.

INSTALLATION POSITION:

Wall & ceiling. Set of 2 x screws and 2 x plugs included.

PRODUCT DIMENSIONS:

D: 40 mm. x H: 38 mm.

PRODUCT WEIGHT:

Base alarm weight (excluding screws, plugs and mounting ring): 40 g.

OPERATION AC/DC:

DC

BATTERY TYPE:

Powered by a non-replaceable 3v CR123A lithium battery 1600mAh

BATTERY LIFE:

Minimum 10 year life in normal operating condition.

POWER CONSUMPTION:

Battery consumption is 82mAh for 1 year in the non alarm condition.

LOW BATTERY INDICATION:

A short acoustic "beep" will sound and LED flash every 48 seconds when the voltage is below 2.85V. In this stage it will continue for minimum 30 days, and can drive the alarm for 4 minutes.

NORMAL OPERATION:

LED flashes every 60 second for normal operation.

SOUND:

Audible indicator min. 85 dB @ 3 meter in anechoic chamber.

VISIBLE AND AUDIBLE INDICATOR:

Normal mode	Short flash green LED every 60sec.	- - - - -
Alarm mode	Sound sweep with red LED	/// /// ///
Test pass	1 sound sweep and green LED will flash for 3sec.	///
Battery fault	1 beep every 60sec. with yellow LED	- - - - -
Sensor fault	2 beeps every 60sec. with yellow LED	- - - - -
End of life of sensor	3 beeps every 60sec. with yellow LED	- - - - -

PUSH BUTTON:

The CO sensor includes a push button switch at the top of the alarm, for easy access.

- hush – during an alarm condition (under a level of 220ppm) this immediately silences the alarm for about 10 minutes when pressed. When battery fault the indication can also be silenced for up to 8 hours by a short press on the hush/test button. This function can only be carried out once during a fault
- test – when not in alarm the sounder can be activated to provide a sensor OK test function. When the top button is released, the audible and visible indicators are activated to show if the sensor is OK. The alarm will also do a self-test every 24 hour

DETECTION TIMING:

Cavius CO-alarm alerts you according to the following levels (PPM=parts per million):
0-50 ppm (green): Safe
50-100ppm (yellow): Alarm starts after 60-90 minutes
100-300ppm (orange): Alarm starts after 10-40 minutes
300+ppm (red): Alarm starts in 3 minutes or less

WARRANTY:

10 year

APPROVALS:

EN50291-1
EN50270
EN60335
RoHS
REACH



CAVIUS

PRODUCT NAME: CAVIUS CO ALARM, 10 YEAR 40MM

PRODUCT NUMBER: 4002

PRODUCT DATA:

CE TESTING INSTITUTE:

LNE

ASSOCIATIONS AND COMMITTEES:

CAVIUS is member of the NF292 committee.

CAVIUS is member of GIFSID, manufacturers' association of domestic fire safety equipment.

OPERATING TEMPERATURE:

+4°C to +38°C (tested from 0 degrees to 55 degrees)

OPERATING HUMIDITY:

Up to 90% RH non-condensing

STORAGE TEMPERATURE:

-20°C to +60°C

STORAGE HUMIDITY:

Up to 93% RH non-condensing

QUALITY ASSURANCE:

SOUND LEVEL:

100% tested in special designed sound chamber.

SENSITIVITY:

100% tested

POWER CONSUMPTION:

100% tested

BATTERY VOLTAGE AND INTERNAL RESISTANCE:

100% tested

ALARM FUNCTION:

100% tested

VISUAL APPEARANCE:

100% tested

PACKING CONTENT:

100% tested

CONTACT

www.cavius.com

MANUFACTURER

Manufacturer: CAVIUS Aps, DK8600

CAVIUS



THE WORLDS
S M A L L E S T
CO ALARM

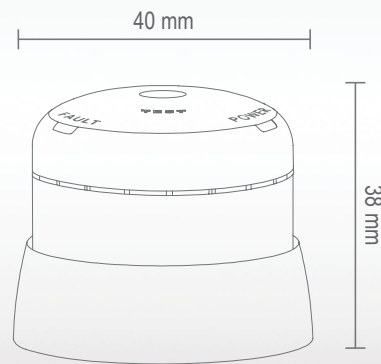

DISTRIBUTOR:

PRODUCT NAME: CAVIUS CO ALARM, 10 YEAR 40MM

PRODUCT NUMBER: 4002